



ZHONGSHENG

## SPECIALIZE IN FRP PULTRUSION

[www.frpzs.com](http://www.frpzs.com)

## HENAN ZHONGSHENG COMPOSITE MATERIAL CO., LTD.

FIBERGLASS PULTRUSION EQUIPMENT · MOLD · PROFILE

### HENAN ZHONGSHENG COMPOSITE MATERIAL CO., LTD.

Add: Intersection of West Ring Road and North Ring Road in Muye District, Xinxiang City.

WhatsApp / Tel: +86 153 0373 5673

E-mail: [Jessica@frpzs.com](mailto:Jessica@frpzs.com)

Web: [www.frpzs.com](http://www.frpzs.com)

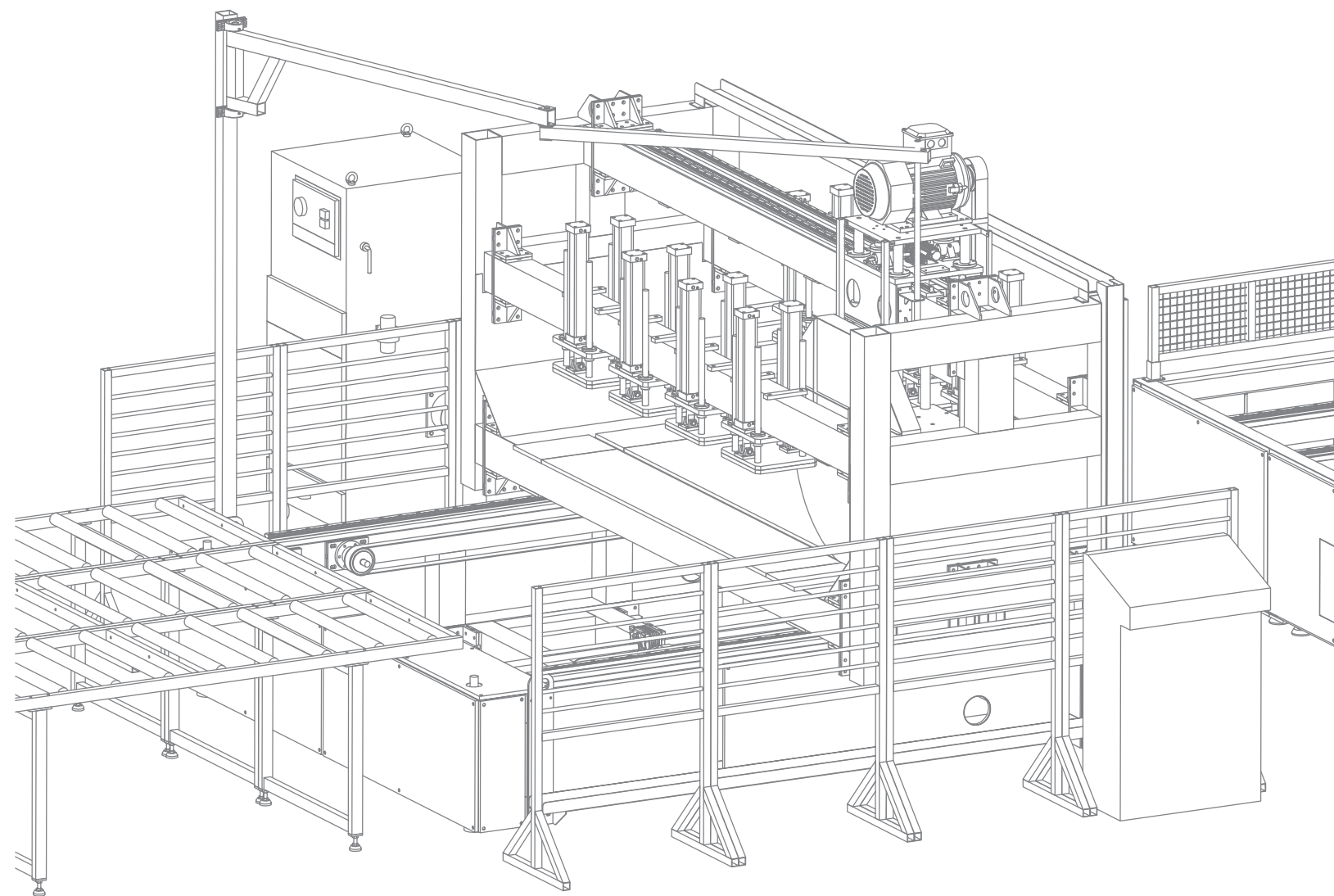

## COMPANY PROFILE

18 Year  
Industry experience

2019 Year  
Start with

20000 m<sup>2</sup>  
Factory area

ISO9001  
Product certification

### SPECIALIZE IN FRP PULTRUSION

Years of research and development have led to the discovery of the true value of polymer composites. We focus on every detail and strive for perfection, taking into account all factors related to composites.

With our sincere understanding of composites,  
we make machines, molds, profiles, and technologies come to life

Henan Zhongsheng Composite Material Co., Ltd., located in Xinxiang City, Henan Province, covers an area of 20,000 square meters and has a registered capital of 15 million yuan. It is an innovative company integrating FRP pultruded profiles, machines, molds, and technology.

The main products include FRP pultrusion machine, FRP pultrusion molds, and the production of polyester, epoxy, and polyurethane pultruded profiles. Our products are sold all over the world. With leading technology, excellent products, and quality after-sales service, Zhongsheng has won the praise of all walks of life and has become a high-quality supplier of FRP pultruded profiles worldwide.

"With exquisite, dedicated to FRP pultruded profiles", we have always been committed to providing customers with high-quality pultrusion machine, high-quality FRP molds, and high-performance profiles, as well as providing technical services and technical support for the industry. We are willing to establish extensive contacts with domestic and foreign companies and institutions, and make new contributions to the development of the global FRP industry together!



# COMPANY STRENGTH

We are always committed to the development and research of pultruded profiles, with advanced production machines, leading processing technology, and strong production capacity, to provide customers with one-of-a-kind solutions.



## ■ TECHNICAL STRENGTH

Zhongsheng is committed to creating high-quality FRP products. Since its inception, we have placed technical research and development work at the top of our priorities. We have a research team with 18 years of industry experience and a technical production team of 91 people, who can control every detail of our products.

## ■ PROCESSING STRENGTH

- 8 machining centers, 7 CNC flat grinders, 5 precision milling machines, 2 wire cutting machines, 2 EDM machines, 2 2.5D inspection instruments and other processing machine more than 40.
- 26 pultrusion production lines, with traction from 3 to 50 tons. Can meet the production of different profile products, stable production capacity.



Equipment Workshop

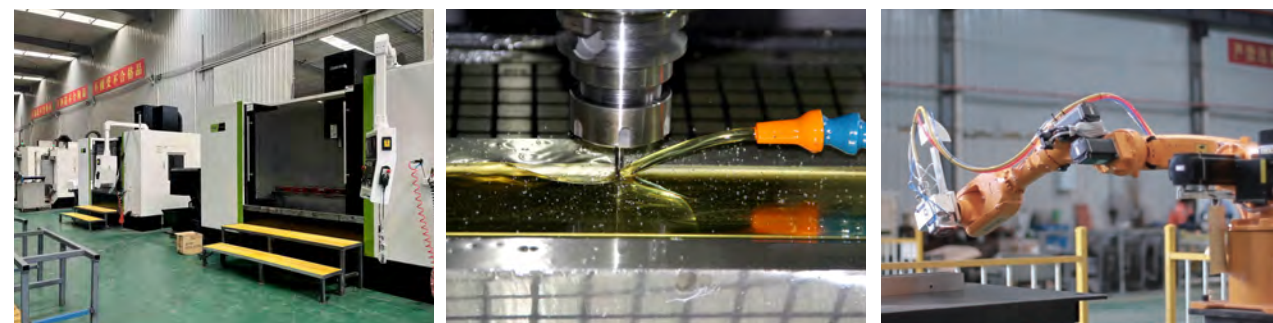

Mold Workshop

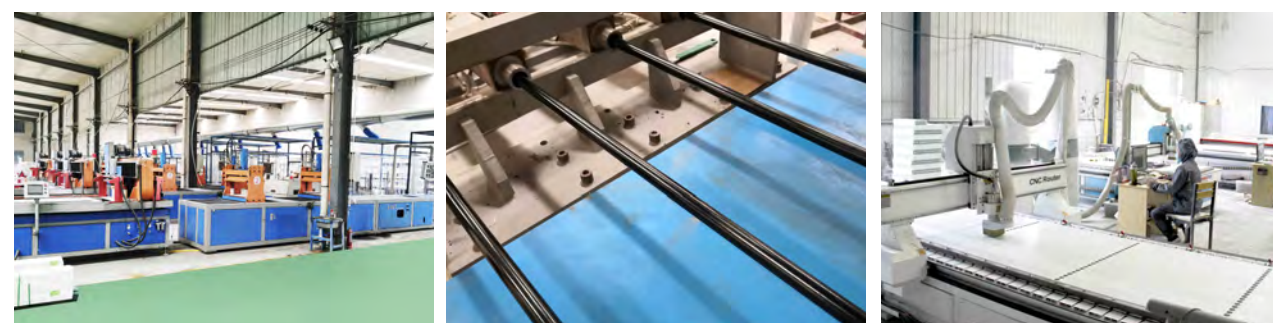

Profile Workshop

# FRP PULTRUSION MACHINE

+86 153 0373 5673

jessica@frpzs.com

www.frpzs.com

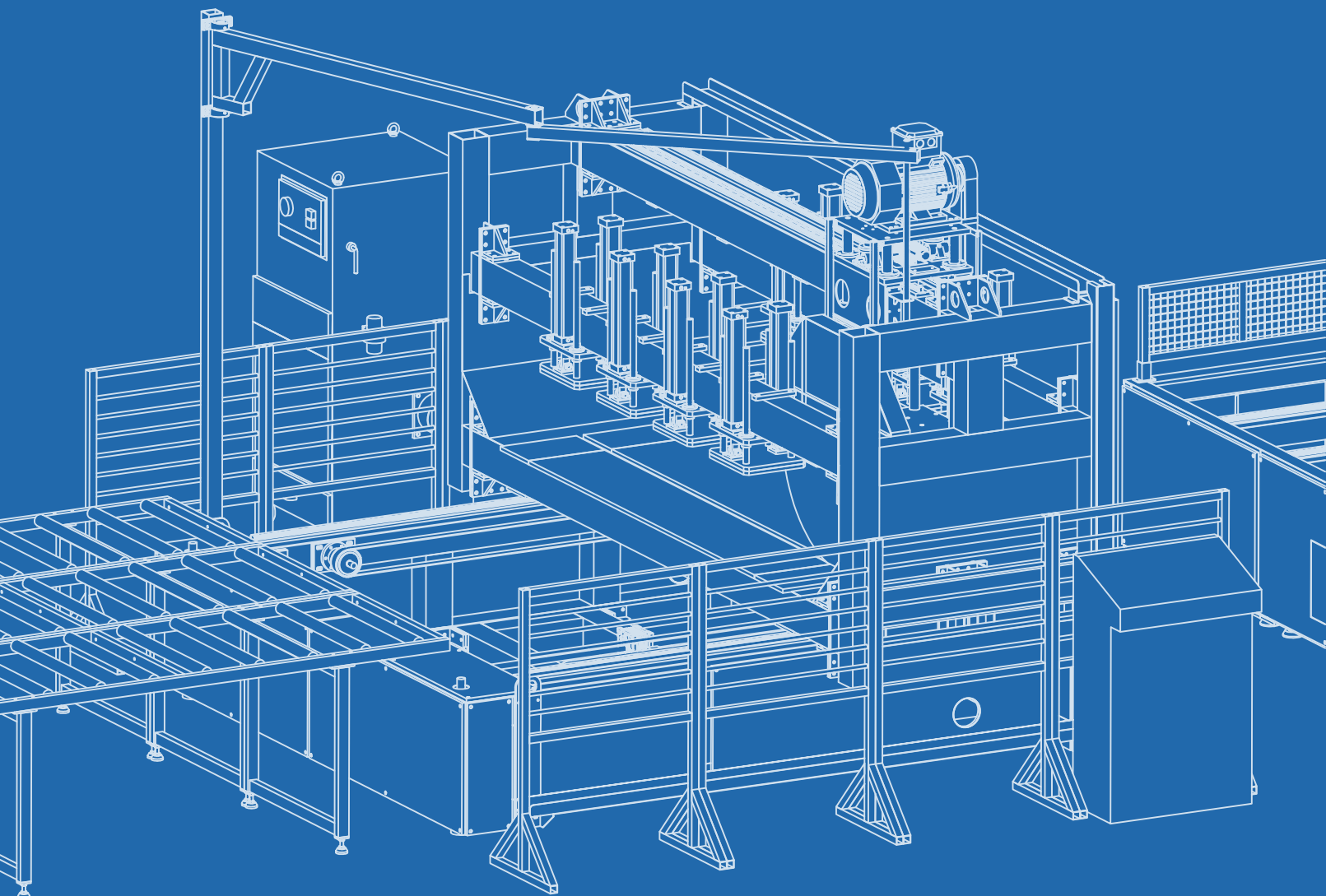

## TRACKED PULTRUSION MACHINE



### MAIN FEATURES:

- Traction drive adopts frequency conversion control, stable operation, energy saving and electricity saving.
- Traction speed is adjusted by knob, quick and convenient.
- The length and width of the track pressure can be customized according to customer requirements.
- Polyurethane clamping block, Barcol hardness  $\geq 85$ , high wear resistance.
- The immersion tank and the forming table can be integrated, with good sealing.

Model		ZS-L5A	ZS-L10A
Traction		50kN	100kN
Clamping Force		70kN	150kN
Holding Zone	Length	2500mm	3000mm
	Width	300mm	300mm
	Height	100mm	100mm
Motor Power		3.7	5.5
Temperature Range		0~250°C	0~250°C
Temperature Accuracy		$\pm 1^\circ\text{C}$	$\pm 1^\circ\text{C}$
Heating Power		24kW/6区	24kW/6区
Total Power		29kW	32kW
External Dimensions	Length	9000mm	10000mm
	Width	1400mm	1400mm
	Height(Traction Section)	1550mm	1550mm
Overall weight		3900kg	4200kg

# GFRP REBAR PRODUCTION MACHINE

## MAIN FEATURES:

- Assembled E glass roving creel stand, equipped with E glass roving tensioning device.
- Immersion pressure E glass roving pneumatic control, simple and convenient.
- The winding part is frequency controlled, which is synchronized with the traction machine in real time.
- The 6 temperature zones of the heating oven are precisely controlled by the temperature control meter.
- The rewinding device can be added or not according to the production process.
- The product adopts water cooling to reduce the temperature, and the cooling speed is fast.
- The crawler type traction machine, frequency conversion control, stable operation.
- The winding and sandblasting devices can be added according to the product process requirements.



Model		XWJ1A	XWJ2A	XWJ4A	XWJ8A
Number of simultaneously produced rebars		1	2	4	8
Diameter Range of Rebars		10--42	10--40	4--16	4--16
Quantity of Roving Stand		1/300 groups	2/300 groups	1/150 groups	2/150 groups
Roving Stand Dimensions	Length	6000mm	6000mm	3000mm	3000mm
	Width	1000mm	1000mm	1000mm	1000mm
	Height	2750mm	2750mm	2750mm	2750mm
Capacity of Resin Impregnation Tank		30kg	20kg*2	40kg	40kg*2
Production Speed		3m/min	5m/min	10m/min	10m/min
Winding Power (kw)		1.1kw+0.75kwX2	2.2kw	2.2kwX2	2.2kwX4
Dimensions of the Winding & Impregnation Section	Length	3730mm	3730mm	3000mm	3000mm
	Width	1100mm	1100mm	1100mm	1100mm
	Height	1850mm	1850mm	1500mm	1500mm
Temperature Control Range		0~250°C	0~250°C	0~250°C	0~250°C
Temperature Accuracy		±3°C	±3°C	±3°C	±3°C
Heating Power		12kw	24kw	24kw	24kw
Heating Section Dimensions	Length	11200mm	11200mm	9430mm	9430mm
	Width	1100mm	1100mm	1100mm	1100mm
	Height	1850mm	1850mm	1850mm	1850mm
Cooling Method		water cooling	water cooling	water cooling	water cooling
Cooling Power (kw)		1.1kw	1.1kw	1.1kw	1.1kw
Cooling Section Dimensions	Length	3000mm	3000mm	2400mm	2400mm
	Width	1100mm	1100mm	1100mm	1100mm
	Height	1200mm	1200mm	1200mm	1200mm
Traction Support Range	Length	2000mm	2000mm	1500mm	1500mm
	Width	200mm	160mm	160mm	160mm
	Height	100mm	100mm	100mm	100mm
Traction Power (kw)		0.75kwX2	0.75kwX4	0.75kwX4	0.75kwX4
Traction Section Dimensions	Length	2500mm	2500mm	2000mm	2000mm
	Width	1100mm	1100mm	1100mm	1100mm
	Height	1850mm	1850mm	1850mm	1850mm
Cutting Range	Width	100mm	100mm	160mm	160mm
	Height	75mm	75mm	75mm	75mm
Cutting Power (kw)		2.2kw	2.2kwX2	2.2kwX2	2.2kwX2
Cutting Section Dimensions	Length	2500mm	2500mm	2500mm	2500mm
	Width	1100mm	1100mm	1100mm	1100mm
	Height	1850mm	1850mm	1500mm	1500mm

# HYDRAULIC PULTRUSION MACHINE



## MAIN FEATURES:

- The whole machine adopts brand PLC control, which is stable and reliable.
- Temperature control adopts high-precision temperature control meter, which is convenient for adjustment and maintenance, and the six-zone control current is displayed in real time.
- The system is equipped with environmental temperature and humidity detection sensors, which can monitor and record environmental temperature and humidity in real time, making it easier to control the pultrusion process.
- The traction control mode includes single gantry reciprocating, double-action gantry reciprocating and double gantry reciprocating alternately.
- The traction speed can be adjusted infinitely through the knob, and the traction operation is stable and the digital display is accurate.
- When the traction force is large, the alternating gantry has no obvious jerking.

Model	ZS-Y10A	ZS-Y20A	ZS-Y30A	ZS-Y50A	ZS-Y100A
Traction	100kN	200kN	300kN	500kN	1000kN
Clamping Force	125kN	250kN	490kN	630kN	1500kN
Holding Zone	Length	600mm	800mm	900mm	1200mm
	Width	600mm	800mm	1000mm	1500mm
	Height	150mm	300mm	400mm	500mm
Motor Power (kw)	3.7X3	5.5X3	7.5X3	11X3	18.5X3
Temperature Range	0~250°C	0~250°C	0~250°C	0~250°C	0~250°C
Temperature Accuracy	±1°C	±1°C	±1°C	±1°C	±1°C
Heating Power (kw)	24kW/6 area	36kW/6 area	48kW/6 area	72kW/6 area	120kW/6 area
Total Power (kw)	39kW	56kW	72kW	107kW	180kW
External Dimensions	Length	11000mm	12500mm	12700mm	12900mm
	Width	1050mm	1200mm	1400mm	1900mm
	Height(Traction Section)	1400mm	2200mm	2200mm	2250mm
Overall weight (kg)	4800kg	8200kg	9300kg	9900kg	13000kg



# QUALIFICATION HONOR

Ensure the stability and reliability of products, and continuously improve market competitiveness. All kinds of qualifications and certificates are complete, the core competitiveness of products is higher, the quality is reliable, the quality is excellent, and it is more at ease to use!



# CORPORATE PURPOSE

## ATTITUDE

Attitude determines height, and customer satisfaction is our satisfaction.

## QUALITY

Quality determines survival, and customer requirements are our requirements.

## ATTITUDE

Details determine success or failure, and customer success is our success. Everything is centered on the customer, correct attitude, ensure quality, and pay attention to details!



**ISO 14001**  
Environmental management system certificate



**ISO 45001**  
Occupational health and safety management system certificate



**ISO 9001**  
Quality management system certificate

+86 153 0373 5673

jessica@frpzs.com

www.frpzs.com

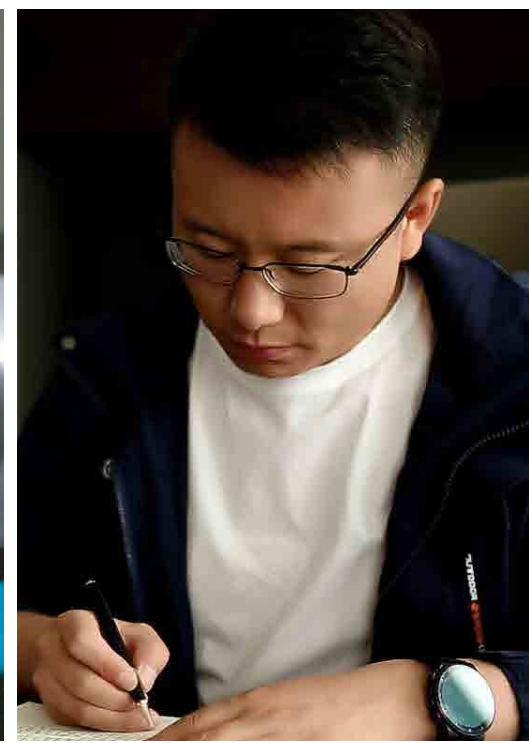

# SERVICE COMMITMENT

Zhongsheng Composite material to fulfill the gold medal service commitment: from pre-sale to after-sales, we will spare no effort to provide you with a total solution and one-stop service



## 1 TO 1 EXCLUSIVE CUSTOMER SERVICE

One-on-one customized services to provide you with For personalized advice and support.



## 7\*24 QUICK RESPONSE

We are online around the clock and at all times, responding promptly to provide you with rational solutions.



## PROFESSIONAL TECHNICAL GUIDANCE

Professional technical team provides you with high-quality pre-sales and after-sales technical support



## PRODUCT QUALITY ASSURANCE

Strict quality management methods to provide you with better products

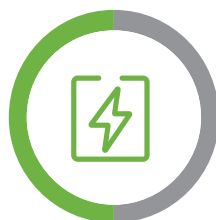

## EXPRESS DIRECT SERVICE

For your urgent needs, we provide you with quick solutions.



## PRODUCT WARRANTY SERVICE

Customized product warranty services give you peace of mind.

# Service Process

Zhongsheng composite is oriented to customer interests, tailor-made solutions, careful and sincere, and boundless service

- 01 Communication consultation
- 02 Technical Exchange
- 03 Scheme design
- 04 Order signing
- 05 Processing and production
- 06 Quality inspection
- 07 Regular follow-up
- 08 Supply and maintenance

